



**Minbos**  
Resources  
Limited

# INVESTOR BRIEF

## IMPACT RETURNS

FEBRUARY 2021



“ PROSPERITY STARTS BY FEEDING THE  
PLANET THAT FEEDS THE PEOPLE. ”



# SCOPING STUDY DISCLAIMER

The Scoping Study referred to in this announcement is a preliminary technical and economic investigation of the potential viability of developing the Cabinda Phosphate Project by constructing an open-pit mine and granulation plant to produce Enhanced Phosphate Rock to supply local agriculture users and Nitrogen/Phosphate/Potassium (NPK) blenders.

It is based on lower level technical and preliminary economic assessments and is insufficient at this stage to support estimation of Ore Reserves, to provide assurance of an economic development case, or to provide certainty that the conclusions of the Study will be realised. The Scoping Study is based on the material assumptions outlined in this report.

The Company believes it has reasonable grounds for disclosing a Production Target given 100% of plant feed mined from the first five years is in the Indicated Resource category and for the Life-of-Mine (LOM), 24% is obtained from Mineral Resource material classified as Measured and 76% as Indicated – there is no Inferred material in the current pit design.

The Scoping Study is based on material assumptions outlined elsewhere in this announcement. These include assumptions about the availability of funding. While the Company considers all the material assumptions to be based on reasonable grounds, there is no certainty that they will prove to be correct or that the range of outcomes indicated by the Scoping Study will be achieved.

To achieve the potential mine development outcomes indicated in the Scoping Study, funding of at least US\$22 million will likely be required. Investors should note that there is no certainty that the Company will be able to raise funding when needed, however the Company has concluded it has a reasonable basis for providing the forward-looking statements included in this announcement and believes that it has a "reasonable basis" to expect it will be able to fund the development of the Project. It is also possible that such funding may only be available on terms that may be dilutive to, or otherwise affect the value of the Company's existing shares. It is also possible that the Company could pursue other strategies to provide alternative funding options. However, the Scoping Study is a project level study and consequently the sources, forms and costs of the capital required to develop the mine have not been accounted for in calculating the financial returns demonstrated by the Scoping Study.

With reference to previously reported Scoping Study Results, the Company confirms that it is not aware of any new information or data that materially affects the information included in the original market announcement and, in the case of material assumptions and technical parameters underpinning the estimates in the relevant market announcement continue to apply and have not materially changed.

Given the uncertainties involved, investors should not make any investment decisions based solely on the results of the Scoping Study. For further details relating to the Scoping Study please refer to ASX release 'Cabinda Phosphate Project Scoping Study' dated 26 August 2020.



# IMPACT INVESTMENT

UNTAPPED AGRI-POTENTIAL DE-RISKED THROUGH AUSTRALIAN MINING FUNDAMENTALS



## LOW CAPEX AND LONG PROJECT LIFE

Pre-production capital less than \$US30M and enough natural phosphate rock for more than 20 years

## ESG APPEAL

Minbos adopts strong reporting framework with global sustainable investment topping \$30 trillion

## STRATEGIC PARTNERSHIP LOCKED

MOU with IFDC to appeal to Development Finance Institutions, Government stakeholders and agribusiness holders

## MINERAL INVESTMENT CONTRACT

Award of project tender is a strong vote of support from Angolan Government for the Minbos fertilizer model

## MIDDLE AFRICA'S AGRICULTURE OPPORTUNITY

Caloric demand from middle Africa's expanding population unmet by local primary agriculture with unutilised arable land and high rainfall and no primary fertilizer manufacturing facility



## COMPELLING STUDY METRICS

NPV (after tax)

US\$159 - 260M

IRR (after tax)

40-58%

CAPEX (pre-production)

US\$22.4 - 27.9M<sup>1</sup>

Dec 2019 - DAP US\$248t

Feb 2021 - DAP US\$497t<sup>2</sup>

<sup>1</sup>Cabinda Phosphate Project Scoping Study – 26 August 2020

<sup>2</sup>DAP fob Tampa via Profercy Phosphates - 4 February 2021

# COMPANY ASX:MNB



## CURRENT CAPITAL STRUCTURE

Shares on Issue	369m
Share Price	10.0cps
Market Cap	A\$37m
Dec 31 Cash	A\$1.7m

## TOP SHAREHOLDERS

	%
Green Innovations	30.5
Peter Wall (Chairman)	3.9
Dave Reeves (Founder)	3.5
Lindsay Reed (CEO)	2.4
Sunset Capital	2.2
Brijohn Nominees Pty Ltd	1.9
S3 Consortium	1.8
HSBC Custody Nominees	1.8
Mr Matthew Norman Bull	1.6
Androlyn Pty Ltd	1.4
<b>TOP 10 SHAREHOLDERS</b>	<b>51.1</b>

ASX:MNB \$0.10 +0.0100 | +11.11% UPDATED 12 Feb 1:59pm

YTD



# CAPITAL STRUCTURE AND USE OF FUNDS



<p><b>Size and Structure</b></p>	<ul style="list-style-type: none"> <li>• Placement to raise approximately \$6.0 million via the issue of 75 million new fully paid ordinary shares. Minbos and the Lead Manager reserve the right to accept oversubscriptions of up to an additional \$1.3 million.             <ul style="list-style-type: none"> <li>• \$4.4 million will be raised via the issue of 55.4 million New Shares pursuant to the Company’s existing placement capacity under ASX Listing Rule 7.1</li> <li>• \$1.6 million will be raised via the issue of 20.0 million New Shares pursuant to the Company’s existing placement capacity under ASX Listing Rule 7.1a</li> </ul> </li> <li>• In addition, investors will, subject to shareholder approval, be issued one new Option (exercise price \$0.15 and expires 2 years from issue ) for every two shares subscribed for. The intention is to list the Options on ASX.</li> </ul>
<p><b>Pricing</b></p>	<ul style="list-style-type: none"> <li>• Offer price of \$0.08 per New Share represents a discount of 17.5% to MNB’s last close of \$0.097 per share on 15 February 2021.</li> </ul>
<p><b>Use of Funds</b></p>	<ul style="list-style-type: none"> <li>• Minbos has confirmed to the Lead Manager that funds raised pursuant to the Offer will be applied towards the completion of the DFS study on the Cabinda Phosphate Project (\$3.5 million) and working capital purposes including the procurement of project finance for the development of the project</li> </ul>
<p><b>Pre-Commitments</b></p>	<ul style="list-style-type: none"> <li>• The Lead Manager has received pre-commitments totalling \$200,000 from directors Mr Peter Wall, Mr Paul McKenzie, and Mr Graeme Robertson.</li> </ul>
<p><b>Lead Manager</b></p>	<ul style="list-style-type: none"> <li>• CPS Capital Group Pty Ltd is acting as the Lead Manager to the Placement.</li> </ul>
<p><b>Disclosure and Secondary Trading</b></p>	<ul style="list-style-type: none"> <li>• New shares issued pursuant to the Placement will be qualified for secondary trading</li> <li>• New shares issued under the Placement will be listed on the ASX and rank pari passu with existing shares (ASX:MNB)</li> </ul>

# IMPACT - FOOTPRINT

ANGOLA & MIDDLE AFRICA UNFERTILIZED POTENTIAL

**+170M**  
population

**226M ha**  
of arable land

**3kg per ha**  
nutrients use

## GROW TO EAT

Small farmers with less than 10 hectares

## GROW TO SELL

Existing and commercial farm sector

## GROW TO EXPORT

Mega farms on infrastructure corridors



# PROJECT RETURNS

## SCOPING STUDY RESULTS

### Asset Overview

Project	Cabinda Phosphate Project
Ownership	Minbos 85%, Local Partner 15% carried.
Location	Cabinda Province, Angola
Commodity	Enhanced Phosphate Rock (EPR)
Infrastructure	Gas, Power, Roads and Regional Port
Mining Target (M&I)	6.5Mt @ 30.2% P <sub>2</sub> O <sub>5</sub> 21 year life <sup>1</sup>

### Scoping Study Results

Production Capacity	150ktpa increasing to 450ktpa
Angolan Market	Currently around 50,000tpa of P <sub>2</sub> O <sub>5</sub>
EPR Price	US\$222 – 290 per tonne
Manufacturing Costs	US\$121 – 141 per tonne (LOM)
Pre production Capex	US\$22.4 – 27.9 million
After Tax NPV	<b>US\$159 – 260 million</b>
After Tax IRR	40 – 58%
Payback	Three years

<sup>1</sup>ASX Announcements – 26 August 2020 Cabinda Phosphate Project Scoping Study <https://www.investi.com.au/api/announc>  
The company confirms there is not material changes to the Mineral Resource or supporting data.

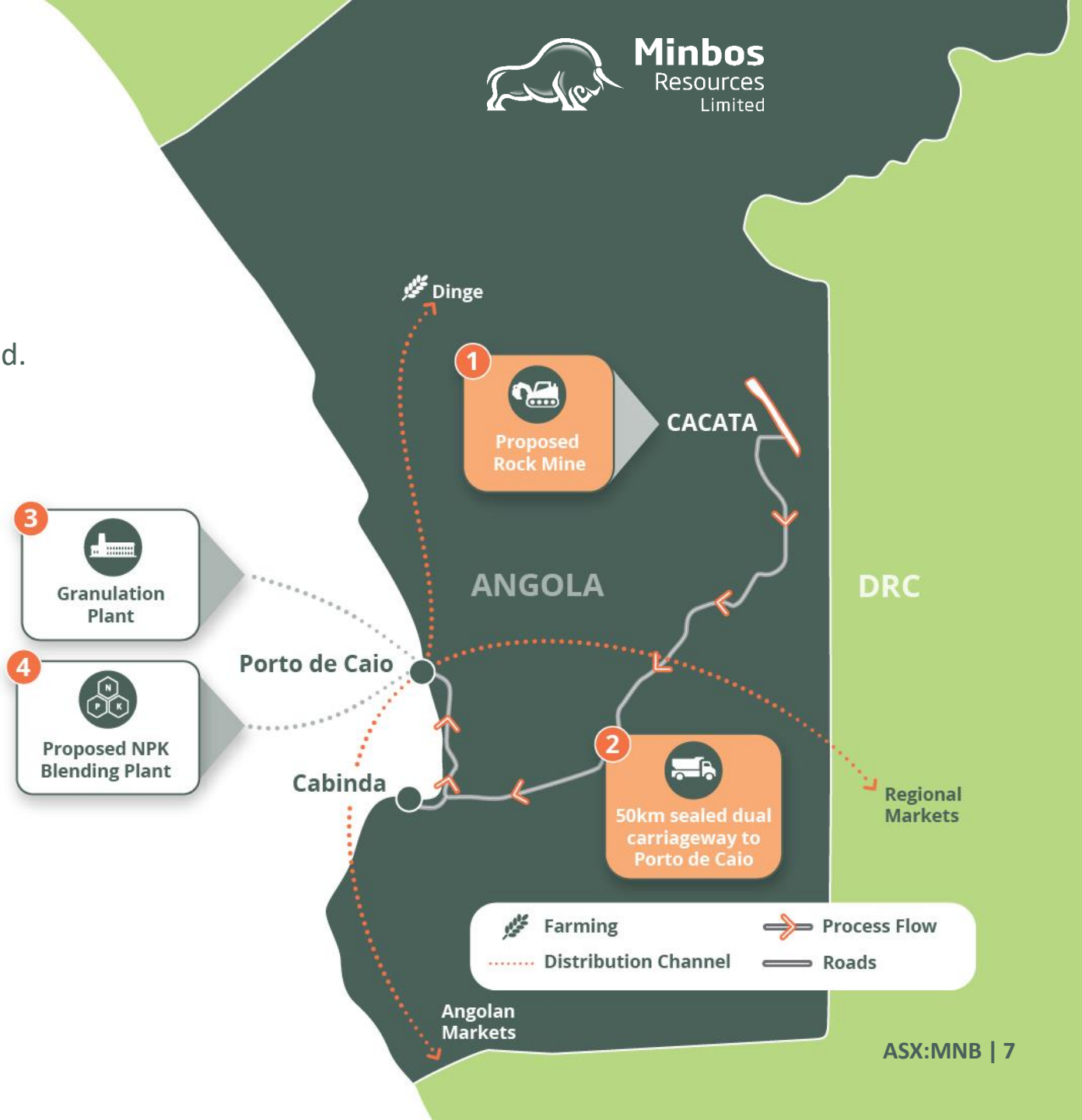

# ENHANCED PHOSPHATE ROCK

OUR ENTRY TICKET TO THE MARKET

**Fit for Purpose** EPR works in P-deficient acid soils, legume and cereal crops, high rainfall climates.

**Tender Mandate** to alleviate poverty for millions of subsistence farmers who use no soil nutrients.

## ENHANCED CABINDA PHOSPHATE ROCK

- ✓ 85% local phosphate rock/15% water soluble phosphate blend
- ✓ **Low-cost**
- ✓ High-solubility
- ✓ Suitable for Angola and wider Congo Basin
- ✓ Combines fast release WSP which solubilises slow-release phosphate rock



100% Phosphate Rock

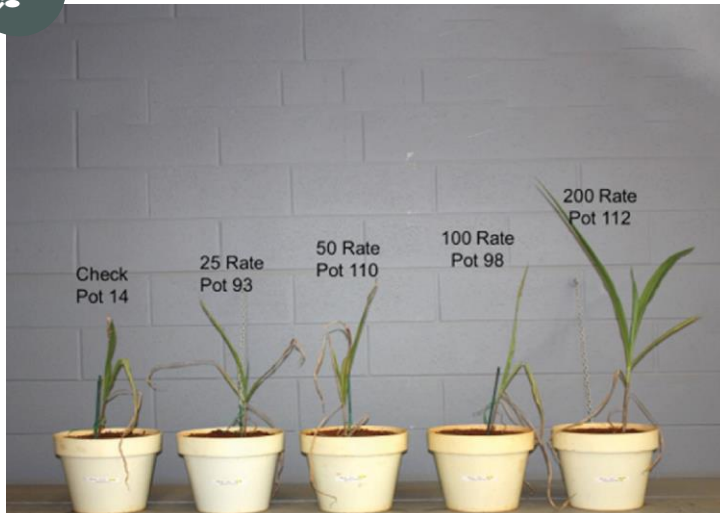

100% WSP Fertilizer

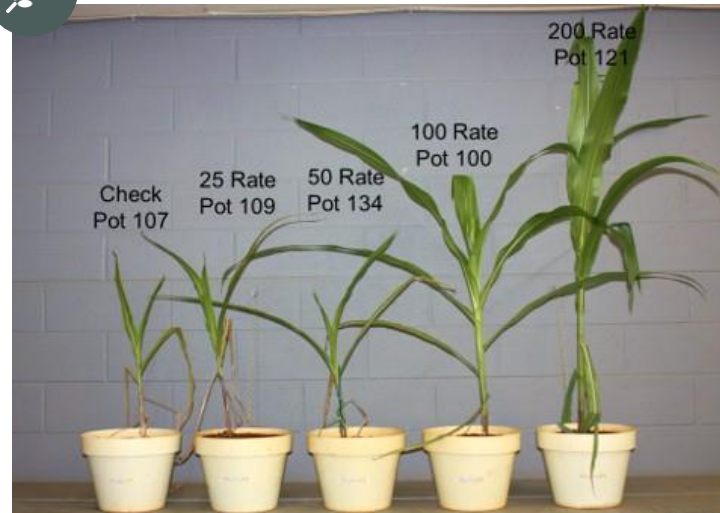

+

=



85% Phosphate Rock | 15% WSP Fertilizer

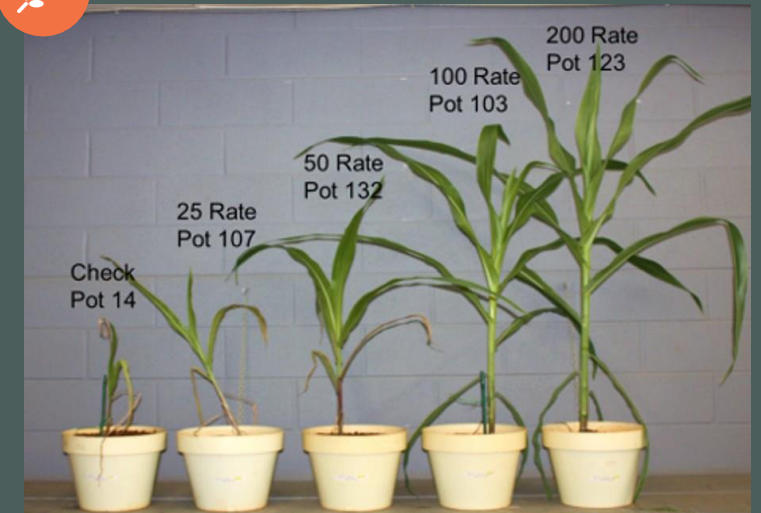



# DEFINITIVE FEASIBILITY

## SIMPLE SCOPE

Granulation plant process design by IFDC, equipment supply by FEECO, engineering by DRA.

Contract Mining and Road Transport based on mine plan and Reserves prepared by Orelogy.

Approvals process in Angola was streamlined last year. Grupo Simples and HCV Africa engaged to complete EIA and ESIA.

**Basis of Preparation** majority of capital and operating costs will be supported by firm quotations from OEM's and principal contractors.

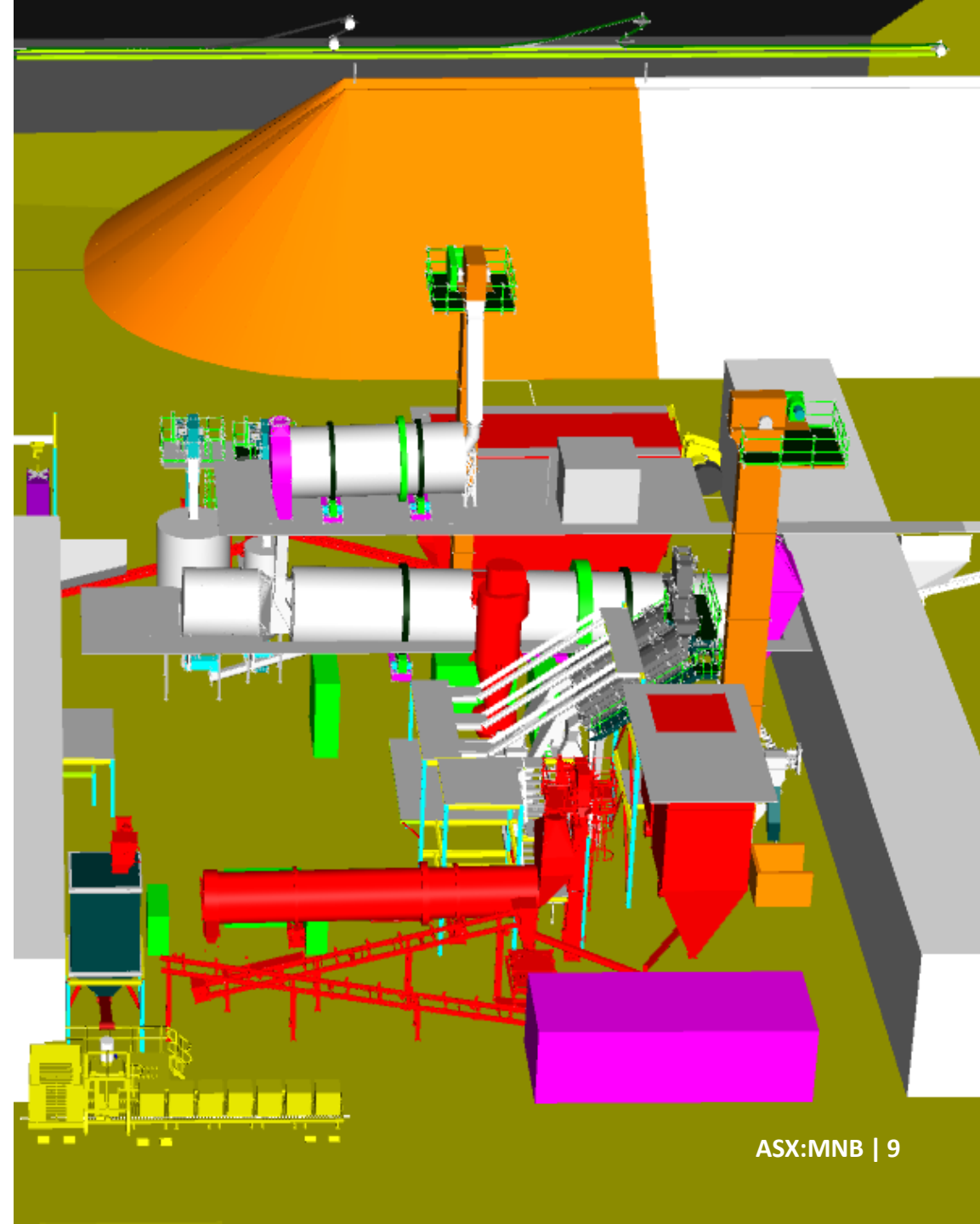

# DEFINITIVE FEASIBILITY BUDGET (US\$)

TWENTY PERCENT COMPLETE (by expenditure)



ITEM	ACTUAL TO DATE	REMAINING	TOTAL
Resource & Mining	\$50k	\$150k	\$200k
Metallurgy & Processing	\$230k	\$540k	\$770k
Infrastructure & Logistics	\$10k	\$100k	\$110k
Industry Analysis and Marketing	\$90k	\$190k	\$280k
Permitting and Approvals	\$30k	\$580k	\$610k
Finance and Funding	\$130k	\$240k	\$370k
Other	\$110k	\$340k	\$450k
Contingency	\$10k	\$560k	\$570k
<b>TOTAL</b>	<b>\$660k</b>	<b>\$2,700k</b>	<b>\$3,360k</b>

# PROJECT SCHEDULE

SIMPLE

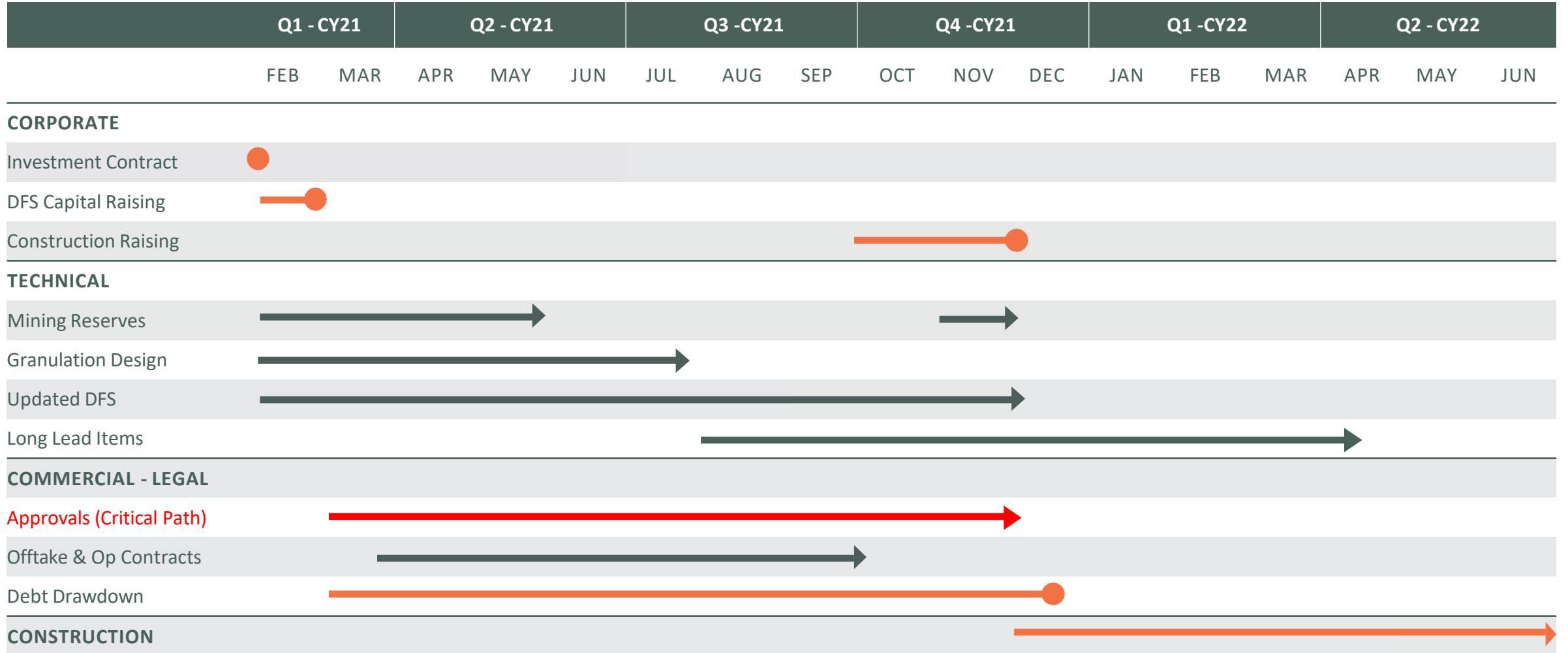

# TARGET MARKETS



**Minbos**  
Resources  
Limited



## GROW TO EAT

- 4 million small farmers
- IFDC Program

## ENHANCED PHOSPHATE ROCK

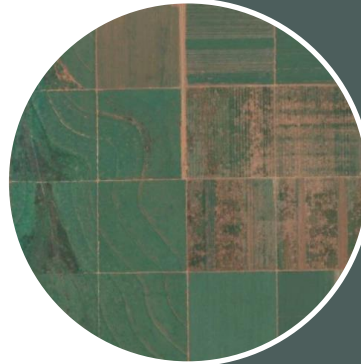

## GROW TO SELL

- NPK product offering
- Blending plant(s)



## GROW TO EXPORT

- Un-utilised high rainfall land
- Existing roads, rail and ports

# IFDC TO DRIVE FERTILIZER CONSUMPTION

MOU TO DEVELOP THE ANGOLAN MARKET



Minbos  
Resources  
Limited

- IFDC recently completed an agricultural productivity program in Burundi where fertilizer usage grew from 10,000tpa -> 50,000tpa
- The program increased agricultural productivity and raised income for 865,666 farming households
- IFDC MOU designed to deliver a scaled-up *Burundi Style* multi-year project to support the development of a small holder fertilizer market in Angola reaching more than 4 million Small Holder Farmers
- Minbos production expected to underpin the fertilizer input component of the IFDC Angola Project

*Given the large Small Holder Farmer market in Angola and the IFDC's strong record of delivering high-impact projects which boost fertilizer usage, demand is expected to exceed the nameplate capacity of 150,000tpa – Minbos ASX Announcement 11 Dec 2020*

MOU GROW TO  
EAT PROGRAM

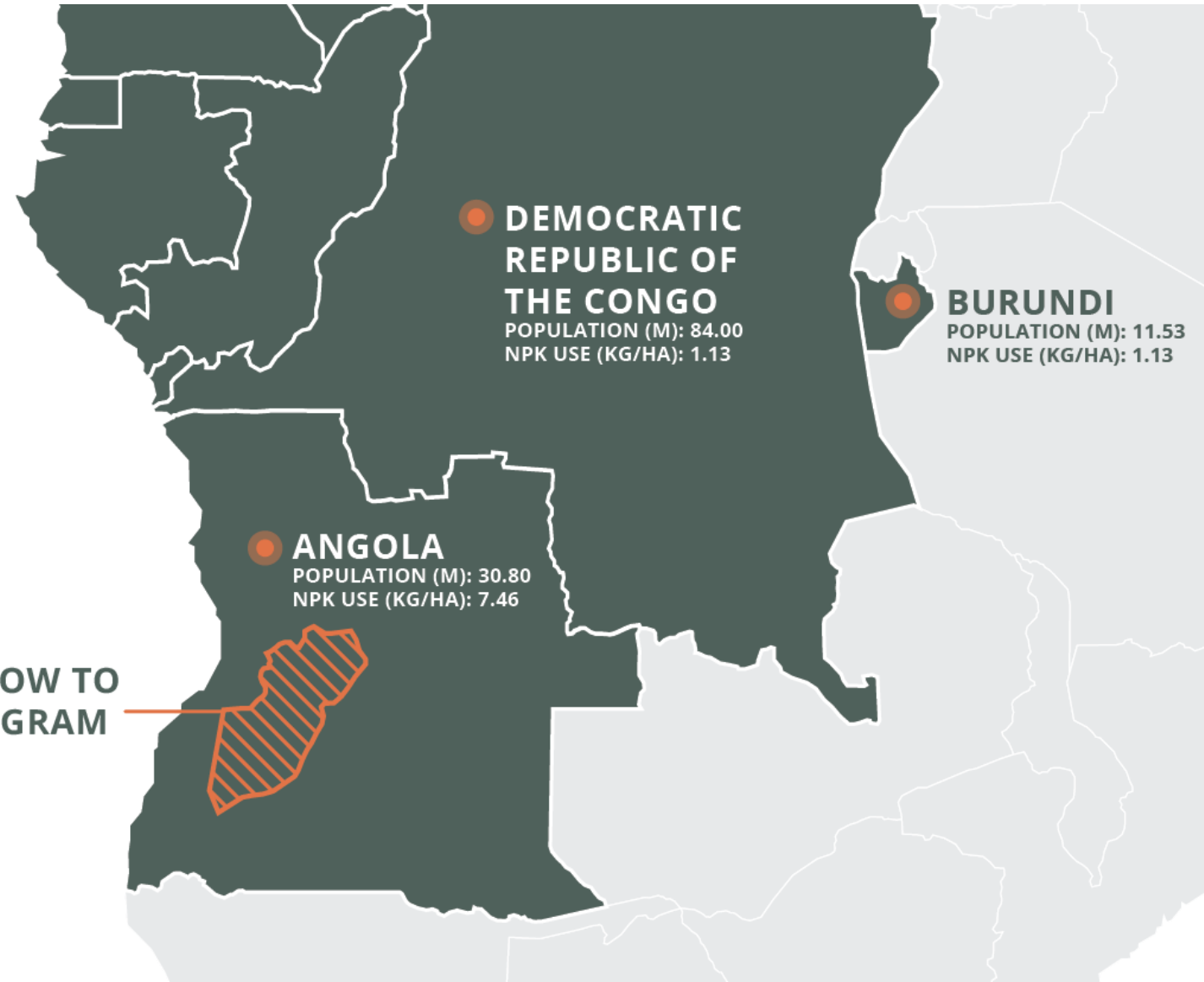

# THE PHOSPHATE MARKET IS RIPPING....



## December 2019

DAP fob Tampa at US\$248 per tonne as Minbos submitted its winning tender for the Cabinda Phosphate Project.

## August 2020

The price increased to US\$328 per tonne as Minbos published the Scoping Study for the Cabinda Phosphate Project.

## February 2021

DAP reached US\$497 per tonne in the first week of February 2021, a doubling of prices since Minbos submitted its successful tender.





# IMPACT FOCUS

## BOARD & MANAGEMENT



### PETER WALL NON-EXECUTIVE CHAIRMAN

Mr Wall is a corporate lawyer and has been a Partner at Steinepreis Paganin (Perth based corporate law firm) since July 2005. Mr Wall graduated from the University of Western Australia in 1998 with a Bachelor of Laws and Bachelor of Commerce (Finance). Mr Wall has also completed a Masters of Applied Finance and Investment with FINSIA. Mr Wall has been or is still the Chairman of a number of ASX listed companies.

### PAUL MCKENZIE NON-EXECUTIVE DIRECTOR

Mr McKenzie is Chairman of Kangaroo Island Plantation (ASX:KPT), Chairman of Hay Australia Pty Ltd, a Director of the SALIC Australia Pty Ltd (Saudi Agricultural and Livestock Investment Co), Chairman of the Cooperative Research Centre for Honey Bee Products Ltd, and Specialist Agri Consultant WA to KPMG.

### GRAEME ROBERTSON NON-EXECUTIVE DIRECTOR

Mr Robertson is the Chairman and CEO of the Intrasia Group of companies established from Singapore and operating from Mauritius, focusing on corporate and financial services as well as the development of growth industries on the African continent. Mr Robertson is a substantial shareholder and former Director of AfrAsia Bank Ltd, a private commercial Bank based in Mauritius which capitalises on financing and trade between Africa and Asia with more than US\$3.5 billion of assets under management. Currently, he is also Non-Executive Chairman of Intra Energy Corp. Ltd for mining development in Africa.

### DAGNIT BALDER NON-EXECUTIVE DIRECTOR

Ms Dganit Baldar is a qualified Israeli corporate lawyer with approximately 20 years experience in the legal profession. Until recently, she was the General Counsel for Mitrelli Group, a multinational organization which initiates, executes and manages large turn-key projects in developing countries.

### VALENTINE CHITALU NON-EXECUTIVE DIRECTOR

Mr Chitalu is the co-founder and Chairman of Phatisa Group, an African-focused private equity fund with ~US400 million funds under management and a well-respected track record of delivering for clients and communities. Phatisa is a proud signatory of the Principles on Responsible Investment which is implemented through a comprehensive ESG framework.

### MR LINDSAY REED CHIEF EXECUTIVE OFFICER

A Mining Engineer with 30 years experience in exploration, development, operations and corporate finance. Lindsay has worked in minerals sands, copper and tin operations obtaining a Mine Managers Certificate. After completing an MBA he worked as a resource analyst in the Australian equity markets. Since then he has started and managed a number of resource companies with projects in a range of commodities in Australia, Africa and Asia.



# WORLD-CLASS PROJECT TEAM

DFS CONSULTANTS AND IN-HOUSE TEAM



## REBECCA MORGAN - MANAGER RAW MATERIALS

Qualified in geology and mining industry including exploration, operations and consulting. She has experience in West Africa and speaks Portuguese. Most recently she worked as a mining consultant with Optiro Resources.

## OLAINDE CAMACHE CATURICHI - COUNTRY MANAGER

Lawyer with more the two decades of experience in Angola working with stakeholders to manage and progress mining and exploration projects.

## STEVE ABBOTT – DFS MANAGER

Mining executive with more than 25 years' experience in senior international and resource sector roles. He has proven technical and management experience at senior levels across exploration, mining, processing, metallurgy, maintenance, smelting, refining, infrastructure, approvals and stakeholder engagement.

## CHRIS SWALLOW – CORPORATE DEVELOPMENT

15 years' experience across both public and private sectors. Most recently Mr Swallow worked in an operational capacity as the Corporate Development Officer for Guinea-focused gold explorer Predictive Discovery.

# ESG FRAMEWORK AND REPORTING

## IMPACT CORPORATE GOVERNANCE FOR THE CABINDA PROJECT

### ESG RISK

climate impact, nature loss, and social unrest around inclusion and working conditions.

### REPORTING

Impact monitoring tech platform “Socialsuite” to streamline the outcomes measurement & ongoing ESG reporting process.

### MINBOS ESG FRAMEWORK

The Board has resolved to adopt the World Economic Forum ESG framework.

### IMPACT INVESTMENT

Global sustainable investment now tops \$30 trillion, up 68% since 2014 and tenfold since 2004.



Principles of Governance

The definition of governance is evolving as organizations are increasingly expected to define and embed their purpose at the centre of their business. But the principles of agency, accountability and stewardship continue to be vital for truly “good governance”.



Planet

An ambition to protect the planet from degradation, including through sustainable consumption and production, sustainably managing its natural resources and taking urgent action on climate change, so that it can support the needs of the present and future generations.



People

An ambition to end poverty and hunger, in all their forms and dimensions, and to ensure that all human beings can fulfil their potential in dignity and equality and in a healthy environment.



Prosperity

An ambition to ensure that all human beings can enjoy prosperous and fulfilling lives and that economic, social and technological progress occurs in harmony with nature.



# SOCIALSUITE ESG REPORT



ASX:MNB

Company

Exploration and development of a phosphata (fertiliser) project in Angola and training local farmers to increase crop yields

COMPANY PERFORMANCE

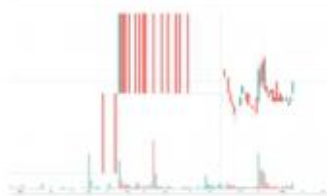

Market cap **\$14.4M**

Price at close **\$0.043**

COMPANY CONTACT DETAILS



Company CEO  
Lindsay Reed

Email Address  
info@minbos.com

Website  
https://www.minbos.com/



For full ESG Report including company Narrative and Explanations please contact the company directly.

LEGEND Action R Reported D Development E Explanation A Audited V Verified

CURRENT QUARTER (BASELINE)

PREVIOUS QUARTER

MATERIAL PRIORITY TIMEFRAME DISCLOSURE MATURITY  
A1 A2 A3 A4 A5

GOVERNANCE



GO-01-A	Setting purpose	Y	N		R	R R R R R R
GO-02-A	Governance body composition	Y	Y	2021	D	R R R R R R
GO-03-A	Material issues impacting stakeholders	Y	N		R	R R R R R R
GO-04-A	Anti-corruption practices	Y	N		R	R R R
GO-04-B	Mechanisms to protect ethical behaviour	Y	N		R	R R
GO-05-A	Integrating risk and opportunity into business process	Y	N		R	R R R R R R

PLANET



PL-01-A	GHG emissions	N	Y	2021	D	R D
PL-01-B	TCFD implementation	N	N		E	
PL-02-A	Land use and ecological sensitivity	Y	N		R	R R R R R R
PL-03-A	Water consumption	Y	N		R	R

PEOPLE



PE-01-A	Diversity and inclusion	Y	N		R	R R R R R R
PE-01-B	Pay equality	N	N		E	R
PE-01-C	Wage level	N	N		E	
PE-01-D	Child, forced or compulsory labour	N	N		E	
PE-02-A	Health and safety	Y	N		R	R R
PE-03-A	Training provided	Y	Y	2021	D	R R

PROSPERITY



PR-01-A	Rate of employment	N	N		E	
PR-01-B	Economic contribution	Y	N		R	R R
PR-01-C	Financial investment contribution	Y	N		R	R R
PR-02-A	Total R&D expenses	Y	N		E	
PR-03-A	Total tax paid	Y	N		E	

ESG PROGRESS DATA WILL BE AVAILABLE NEXT QUARTER



**Minbos**  
Resources  
Limited

**“THE BEST WAY TO  
MAKE A DIFFERENCE  
IS TO HELP  
SOMEONE ELSE  
MAKE A LIVING.”**

**LINDSAY REED  
CEO MINBOS RESOURCES LTD**



# COMPETENT PERSON'S STATEMENT

The Competent Person with responsibility for the total Mineral Resources of this report is Mrs Kathleen Body, Pr. Sci. Nat, who is an employee of Red Bush Analytics. Mrs Body was a full time employee of Coffey Mining at the time the original Mineral Resource estimation was completed in 2013. Mrs Body has 25 years' experience in the mining industry and has sufficient experience which is relevant to the style of mineralization and type of deposit under consideration and to the activity which she is undertaking to qualify as a Competent Person as defined in the 2012 Edition of the "Australasian Code for Reporting of Exploration Results, Mineral Resources and Mineral Reserves. Kathleen Body consents to the inclusion in the report of the matters based on his/her information in the form and context in which it appears.

The information in this announcement that relates to the Mineral Resources contained within the Production Target, complies with the 2012 Edition of the Australasian Code for Reporting of Exploration Results, Mineral Resources and Ore Reserves (**JORC Code**) and has been compiled, and assessed by Mr Ross Cheyne BEng (Hons), Mining, a Fellow of the Australian Institute of Mining and Metallurgy (AusIMM) and Technical Director at Oreology Mine Consulting Pty Ltd, consultants to the Company. Mr Cheyne has sufficient experience that is relevant to the style of mineralisation and type of deposit under consideration and to the activity being undertaken to qualify as a Competent Person as defined in the 2012 Edition of the JORC Code. Mr Cheyne is the competent person for the Mineral Resources contained within the Production Target and the Production Target itself and has relied on provided information and data from the Company, including but not limited to the Resource model and database. Mr Cheyne consents to the inclusion in this announcement of matters based on his information in the form and context in which it appears.

## DISCLAIMER

Some of the statements appearing in this announcement may be in the nature of forward-looking statements. You should be aware that such statements are only predictions and are subject to inherent risks and uncertainties. Those risks and uncertainties include factors and risks specific to the industries in which Minbos operates and proposes to operate as well as general economic conditions, prevailing exchange rates and interest rates and conditions in the financial markets, among other things. Actual events or results may differ materially from the events or results expressed or implied in any forward-looking statement. No forward-looking statement is a guarantee or representation as to future performance or any other future matters, which will be influenced by a number of factors and subject to various uncertainties and contingencies, many of which will be outside Minbos's control.

Minbos does not undertake any obligation to update publicly or release any revisions to these forward looking statements to reflect events or circumstances after today's date or to reflect the occurrence of unanticipated events. No representation or warranty, express or implied, is made as to the fairness, accuracy, completeness or correctness of the information, opinions or conclusions contained in this announcement. To the maximum extent permitted by law, none of Minbos, its Directors, employees, advisors or agents, nor any other person, accepts any liability for any loss arising from the use of the information contained in this announcement. You are cautioned not to place undue reliance on any forward-looking statement. The forward-looking statements in this announcement reflect views held only as at the date of this announcement.

This announcement is not an offer, invitation or recommendation to subscribe for, or purchase securities by Minbos. Nor does this announcement constitute investment or financial product advice (nor tax, accounting or legal advice) and is not intended to be used for the basis of making an investment decision. Investors should obtain their own advice before making any investment decision.

# Key Risks

Note: Please refer to the Company's Scoping Study announcement released on ASX on 26 August 2020 for further details on the risks and other factors that may affect the outcomes for the Company's Phosphate Project in Angola



COMPANY SPECIFIC
<p><b>Coronavirus (COVID-19):</b> The outbreak of the coronavirus (COVID-19) is impacting global economic markets. The nature and extent of the effect of the outbreak on the performance of the Company remains unknown. The Company's Share price may be adversely affected in the short to medium term by the economic uncertainty caused by COVID-19. Further, any governmental or industry measures taken in response to COVID-19 may adversely impact the Company's operations and are likely to be beyond the control of the Company. In addition, the effects of COVID-19 on the Company's Share price and global financial markets generally may also affect the Company's ability to raise equity or debt or require the Company to issue capital at a discount, which may in turn cause dilution to Shareholders or the COVID-19 pandemic may also give rise to issues, delays or restrictions in relation to land access and the Company's ability to freely move people and equipment to and from exploration projects may cause delays or cost increases.</p>
<p><b>Project Risks:</b> On 26 August 2020, the Company released on ASX an announcement titled "Cabinda Phosphate Project Scoping Study", which set out a summary of the results of the Company's Scoping Study (Scoping Study). Investors are directed to this announcement for details of these risks and other factors that may impact the Company's ability to develop the Cabinda Phosphate Project, which include, without limitation, matters relating to capital costs, exchange rates, operating costs, environmental issues, access to port and infrastructure, water and power supply, and ability to secure off-take. These project risks should be considered by all investors prior to making an investment decision.</p>
<p><b>Reliance on key personnel:</b> The responsibility of overseeing the day-to-day operations and the strategic management of the Company depends substantially on its senior management and its key personnel. There can be no assurance given that there will be no detrimental impact on the Company if one or more of these employees cease their employment.</p>
<p><b>Additional requirements for capital:</b> The Company's capital requirements depend on numerous factors. The capital raising is intended to fund the Company's operations through to completion of the DFS. However, there is a risk that the costs of completing the DFS will exceed budgeted costs, which may require the Company to raise additional capital. In any event, the Company will likely require further financing in addition to amounts raised under the capital raising should it require further engineering study work or move to project construction following completion of the DFS.</p> <p>In addition, in order to move the project forward after completion of the DFS, a significant fundraising will be required as outlined in the Scoping Study.</p> <p>Any additional equity financing will dilute shareholdings, and debt financing, if available, may involve restrictions on financing and operating activities. If the Company is unable to obtain additional financing as needed, it may be required to reduce the scope of its operations and scale back its development and research programs as the case may be. There is however no guarantee that the Company will be able to secure any additional funding or be able to secure funding on terms favourable to the Company.</p>
<p><b>Other Company Risks:</b> On 18 September 2020, the Company released its Annual Report for the year ended 30 June 2020 to ASX. The Annual Report detailed a number of industry specific risks to the Company including, without limitation, those relating to Operating Risks, Environment Risks, Economic Risks, Market Conditions, Additional Requirements for Capital, Speculative Investment, Risks with Operating in Angola and Madagascar, the Legal Environment in Angola and Madagascar, Lack of Specific Infrastructure, Workforce and Labour Risks and Renewals of Permits in Madagascar. Investors are urged to read the risk factors carefully in the Annual Report.</p>
GENERAL RISKS
<p>There are also a number of general risks that apply to the Company, including, without limitation, those relating to economic conditions and other global or national issues, market conditions generally, climate change risks, insurance risks, Government policy changes, ability to pay future dividends and taxation.</p>